



SAFE LOCATION OF OXYGEN AND INERT GAS VENTS

AIGA 067/10

Globally Harmonised Document

Asia Industrial Gases Association

3 HarbourFront Place, #09-04 HarbourFront Tower 2, Singapore 099254
Tel : +65 6276 0160 • Fax : +65 6274 9379
Internet : <http://www.asiaiga.org>



SAFE LOCATION OF OXYGEN AND INERT GAS VENTS

PREPARED BY:

Roger Argent	AIR PRODUCTS
Lorenzo Beretta	SOL
Alfredo Delgado	PRAXAIR
Alexandre Morainville	AIR LIQUIDE
Harald Weckler	LINDE GROUP

Disclaimer

All publications of AIGA or bearing AIGA's name contain information, including Codes of Practice, safety procedures and other technical information, that were obtained from sources believed by AIGA to be reliable and/or based on technical information and experience currently available from members of AIGA and others at the date of the publication. As such, we do not make any representation or warranty nor accept any liability as to the accuracy, completeness or correctness of the information contained in these publications.

While AIGA recommends that its members refer to or use its publications, such reference to or use thereof by its members or third parties is purely voluntary and not binding.

AIGA or its members make no guarantee of the results and assume no liability or responsibility in connection with the reference to or use of information or suggestions contained in AIGA's publications.

AIGA has no control whatsoever with regards to performance or non performance, misinterpretation, proper or improper use of any information or suggestions contained in AIGA's publications by any person or entity (including AIGA members), and AIGA expressly disclaims any liability in connection thereto.

AIGA's publications are subject to periodic review and users are advised to obtain the latest edition.

Acknowledgement

This document is adopted from the European Industrial Gases Association document IGC 154/09 'Safe location of oxygen and inert gas vents'. Acknowledgement and thanks are hereby given to EIGA for permission granted for the use of the document.

Table of Contents

1	Introduction	1
2	Scope and purpose.....	1
2.1	Scope.....	1
2.2	Purpose.....	1
3	Definitions	1
3.1	Verbal forms	1
3.2	Pressure.....	2
4	Hazards of oxygen enrichment or deficiency of the atmosphere.....	2
5	Factors for consideration in the location of vents	3
5.1	General considerations.....	3
5.2	Selection of concentration criteria for specific circumstances	4
5.3	Vent locations	4
5.4	Effect of weather and release conditions.....	5
5.5	Venting of cryogenic liquid.....	6
6	Calculations for the determination of safe vent locations	6
6.1	Introduction	6
6.2	Choice of software	7
6.3	Weather conditions	7
6.4	Release temperature	7
6.5	Release angle.....	8
6.6	Release velocities.....	8
6.7	Concentration limits	9
6.8	Ambient conditions	9
6.9	Interpretation of the tables	10
6.10	Limitations on the calculation methodology.....	14
7	Conclusions	14
8	References.....	15
	Appendix A: Warm Low Pressure Oxygen.....	16
	Appendix B: Cold Low Pressure Oxygen.....	19
	Appendix C: Warm High Pressure Oxygen.....	22
	Appendix D: Cold High Pressure Oxygen.....	23
	Appendix E: Warm Low Pressure Nitrogen	24
	Appendix F: Cold Low Pressure Nitrogen.....	27
	Appendix G: Warm High Pressure Nitrogen	30
	Appendix H: Cold High Pressure Nitrogen.....	31
	Appendix I: Warm Low Pressure Argon.....	32
	Appendix J: Cold Low Pressure Argon	34
	Appendix K: Warm High Pressure Argon.....	36
	Appendix L: Cold High Pressure Argon	37

APPENDIX M: Equivalent Release Rates 38

APPENDIX N: Influence of Release Speed..... 41

APPENDIX O: O₂ Adjustment Mathematics 42

1 Introduction

This document defines the criteria for the design of process vents to ensure safe disposal of non-toxic, non-flammable gases.

The industrial gas producers are subject to more and more stringent demands from authorities to demonstrate that the operation of their plants is safe. A number of accidents have been reported [1, 2] where enriched or deficient atmospheres from venting operations have created operational safety issues. As air separation unit capacity has increased the risk of oxygen enriched and deficient atmospheres has become a more significant safety concern.

2 Scope and purpose

2.1 Scope

This document applies to air separation and cryogenic liquefaction plants in which the venting of oxygen, nitrogen, oxygen/nitrogen mixtures, argon, or air occurs.

Disposal of cryogenic liquid is not covered in this document although the potential for vent releases to have some liquid present is included (Section 5.5).

The application of this document for non-flammable and non-toxic gases other than oxygen, nitrogen, argon, or air has to be assessed on a case-by-case basis.

The recommendations contained in this document for elevations and horizontal separation distances are not applicable to customer station tanks. Safety distances for such tanks are governed by the design criteria for plant layout [3] or national regulations/codes of practice whichever are more stringent.

2.2 Purpose

This document is designed to give a basis on which to determine the safe location of oxygen or asphyxiating nitrogen and argon gas vents for normal operating, upset and emergency conditions. The determination can be by calculation against the criteria specified or by use of the look-up tables provided in the document as a guide.

The document contains calculated safe separation distances for a range of vent sizes and orientations based on commonly encountered but specific design conditions. If these design criteria are not met particularly with regard to vents intended to operate over a large range of flows (e.g. product vents having turndown flows) the tables may not be appropriate and detailed calculations should be carried out.

This document should be used for new designs but can be used on existing plants to determine whether existing vents are safely located or whether modifications/temporary structures will interfere with the original design intent.

3 Definitions

3.1 Verbal forms

“Shall” is used when conformance to a specific recommendation is mandatory. (French: “doit”; German: “muss”).

“Should” indicates a recommendation to follow the specified procedure. (French: “devrait”; German: “sollte”).

“May” is used when the application is optional. (French: “peut” ; German: “darf”, “kann”).

3.2 Pressure

In this document bar indicates gauge pressure unless otherwise noted –i.e., (bar, abs) for absolute pressure and (bar, dif) for differential pressure.

4 Hazards of oxygen enrichment or deficiency of the atmosphere

Oxygen, which is essential to life, is not flammable in itself but supports and accelerates combustion.

Oxygen reacts with most materials. As the oxygen concentration in air increases the potential fire risk increases: the more vigorously the combustion reaction or fire takes place, the lower the ignition temperature and the ignition energy to get the combustion reaction started, and the higher the flame temperature and destructive capacity of the flame.

If the oxygen concentration in air decreases, or (what amounts to the same) if the concentration of inert gases increases, a situation is rapidly reached where the hazards of asphyxia become very great. Lack of oxygen may cause vertigo, speech difficulties but the victim does not recognise these symptoms as asphyxiation. For an unwary person, the asphyxiating effect of inert gases takes place without any preliminary physiological sign that could alert the victim. This action is very rapid: only a few seconds for very low oxygen contents.

The hazards from oxygen enrichment or deficiency are explained in the AIGA documents “Fire hazards of oxygen and oxygen enriched atmospheres” [4] and “Hazard of inert gases” [5].

The AIGA position paper “Definitions of oxygen enrichment/deficiency safety criteria” [6] provides the following guidance for selecting the appropriate level of oxygen for particular scenarios.

The AIGA documents and the position paper state the measures that should be taken for a confined space entry.

- The maximum safe concentration for entry into a confined space that is being controlled or measured because of the risk is 23.5% total O₂.
- The minimum safe oxygen concentration for entry into a [confined] space that is being controlled or measured because of the risk is 19.5% total O₂.
- The space should be ventilated sufficiently to obtain a value approaching 21% O₂ (i.e. indistinguishable from atmospheric air).

Vents are distinguished separately in the position paper on the basis of the acceptability of minimal risk.

For venting situations the following definitions are used.

- For cases of leakage, venting or uncontrolled release of oxygen into the atmosphere, there is no risk of harm in clouds containing up to 25% O₂. At anticipated level above 25% O₂ it may be possible by means of risk assessments to determine that such atmospheres can be safely entered with appropriate control e.g. there is no permitted smoking in an area where venting is possible or hot work is controlled by a permit because of the risks of venting.
- For cases of leakage, venting or uncontrolled release of inert gases into the outdoor atmosphere, there is no anticipated risk of harm in clouds containing at least 17% O₂.

The values provided in the position paper are the basis of the calculations given in this document (see Section 6.7 below). The choice of concentration limits acceptable for vent location design is discussed in the following section.

5 Factors for consideration in the location of vents

5.1 General considerations

The safe location of any vent to atmosphere will be dependent on the venting conditions, the hazards associated with the gas at the vent conditions, the vent use frequency, and environmental considerations resulting from the gas being released. From these will come decisions on vent height and orientation relative to surrounding equipment, personnel access areas and prevailing wind direction. Consideration has also to be given to the effects of any release outside the plant boundary where the risks will be affected by the nature of the surrounding area (industrial, commercial, urban or country conditions) as well as the numbers of people that might be subject to any release.

The following hazards will be associated with vented atmospheric gases from industrial gas operations:

- Asphyxiation (nitrogen and argon)
- Enhanced fire risk (oxygen)
- Cold and low visibility (cryogenic gases and liquids)
- Hot gases (e.g., compressor interstage relief/discharge gas vents)

Note: Gases or mixtures containing flammable or toxic components such as hydrogen, carbon monoxide or carbon dioxide can be discharged from operations involving atmospheric gas processing but venting of these is NOT covered by this standard.

Vent use frequency can be categorised in the following terms:

- Continuous
- Intermittent in normal operation
- Commissioning/startup/shutdown
- Performance testing
- Emergency pressure relief
- Emergency depressurisation

In general only those vents that are either within the total control of the plant operation such as vents operated manually on an intermittent basis (e.g., startup, shutdown, tanker fill), or that will be expected to be open for a short duration protection (e.g., pressure-relief devices, automatic dumps) can be assessed as being on a non-continuous basis.

In addition the influence of exit velocity is important where gases being vented at the warm-end of an Air Separation Unit (ASU) can be vented at any flow rate between the nominal design capacity and zero (such reduced venting flow rates are typically met during the adaptation period of the ASU after a sudden change of the client demand or when the nitrogen/oxygen ratio of the client demand does not match with the ASU production ratio). Therefore, the correct design of the vent stack of the separated gas streams exiting the warm-end of an ASU must take into account the potential reduced flow rates in normal operation when determining the vertical height of the vent. See Section 6.6 and Appendix N for further information on this point.

Environmental protection considerations include:

- Acceptable noise and odour levels
- Visibility of emission
- Local and national authority requirements

Consideration may be required as to whether the plant is unmanned in determining the proper disposal of vented gases because remedial action in the event of a gas release may be delayed. In general the risks from venting on an unmanned plant should be no different from a fully attended facility because the periodic presence of people cannot be ignored.

The risk of damage to adjacent equipment or injury to people has to be determined taking all the above factors into account.

The following sub-sections give more detailed consideration to the factors involved in safely locating atmospheric vents.

5.2 Selection of concentration criteria for specific circumstances

Vent locations shall be determined in relation to the hazards of oxygen or inert gas releases given in Section 4. On the basis of the risks from various gas concentrations summarised there, organisations may set their own concentration limits for the various vent types taking account of the general considerations given in Section 5.1, and based on their own safety philosophy.

In principle, the general public should not be subject to any potential risk above that resulting from their normal activities, and so consideration shall be given to ensuring that all identifiable vent release cases do not give oxygen concentrations outside the range of 19.5 to 23.5 volume % oxygen at ground level outside the plant boundary or at the height of buildings adjacent the property line. These limits may also apply to adjacent industrial sites but for customer premises where the air separation plant products are being piped it can be appropriate to treat the risks from gas vents as being the same as within the air separation plant boundary.

Within the plant boundary, management controls of such items as naked flames, grinding or welding, and smoking should allow a higher oxygen concentration from any vents to be acceptable at all normally accessible points within a facility. The recommended value is a maximum expected concentration of 25 volume % oxygen for all identified vent cases (as reference 6)

Similarly, the risk from exposure to low oxygen concentrations (inert gas releases) can be controlled within a plant (from reference 6). For vent locations with known release conditions it is recommended that a minimum expected oxygen concentration of 17 volume % oxygen be used as the design basis for all vents. Consideration may be given to increasing this limit to a higher value in order to provide safety margins for the effect of unknowns in the release cases or atmospheric conditions in making such an evaluation. The calculations described in Section 6 give inert gas dispersion limits to 18% O₂ as a guide as well as for 19.5% and 17% O₂.

National or local regulations may specify different concentration limits for exposure, in which case these would supersede any criteria recommended above.

The effects of variations in the release conditions are discussed further below.

5.3 Vent locations

In general, vents shall be orientated such that the discharge gases, warm or cold, cannot impinge directly on personnel, structures, working areas or equipment.

The following is a summary of experience during engineering and operation of air separation plants.

- Ingress of vented gas into process air intakes, buildings, and air conditioning/ventilation systems shall be avoided.
- Vents from equipment situated inside totally enclosed rooms or buildings should be piped to outside locations unless appropriate preventative measures against concentration buildup are adopted. .
- Vents should be located so as not to expose personnel on access platforms or walkways to the hazards of oxygen enriched or deficient atmospheres.
- Separation distances between oxygen vents and flammable gas vents of adjacent plants shall be considered to avoid the risk from the effects of enhanced combustion.

- Separation distances between oxygen vents and flare systems of adjacent plants are required.
- Even though the vertical release of a vent gives the best location in relation to height it is often useful to provide the vent outlet with an angle to give the gas stream a specific release direction e.g. away from a supporting structure such as a coldbox.
- If the vent outlets are located adjacent to or between taller constructions such as buildings which are relatively close, the vent heights should be clearly above the top of the taller structure independent of whatever height is obtained by calculation. The influence of obstacles to unrestricted venting may need a specific assessment.
- High pressure non continuous vents (e.g., safety valves outlets) shall not be directed at platforms, ladders or other access points, and not directly blow onto equipment. This is to prevent injury to persons and damage to equipment from high velocities even if a risk from air enrichment is not anticipated.
- Even if safely located with regards dispersion, vent outlets (particularly at high pressure) can be a noise hazard. Vent position and orientation shall account for both the environmental and occupational health effects of noisy releases.
- It must be recognized that usual dispersion calculations take no account of vents located on or at the side of buildings in the area of which flow patterns across roofs can give rise to downdrafts of air flow. The likelihood of downdraft flow patterns should be considered during the design phase and the location of vents selected to minimize or eliminate any adverse effects on the gas dispersion plume.
- Vents released at higher elevations will be exposed to a higher local wind speed than those released at lower elevations. Greater turbulence due to higher wind velocity at higher release elevation will tend to cause releases at higher elevations to disperse more readily. Reduced separation distances may be justified for elevated platforms if the vent location is relatively high off the ground but it must be determined through a detailed study

Particular care needs to be taken with plant modifications, including erection of temporary structures to gain access to maintenance or modification work, to ensure that changes in the plant do not make the locations of existing vents unsafe with regards orientation. Existing vent locations need to be fully reassessed if the vent cases are likely to change as a result of the modification.

In any case that under worst conditions an enrichment of O₂ / N₂ has to be expected a sign should be posted at the base of ladders and access points giving a warning concerning possible asphyxiating/ oxygen enriched atmosphere beyond such a point. The location and arrangement of such vents and the disposition of warning signs should be the subject of a safety review. Portable air monitoring instruments should be worn during access to such areas

By design, continuous, large-capacity process vents, such as oxygen, waste and low-pressure nitrogen, may be grouped in one general area to make use of a common support structure. Normal vent location selection criteria would not generally account for several or all of these vents operating at the same time. Special consideration may be required for such arrangements.

5.4 Effect of weather and release conditions

The following weather factors can have a detrimental effect to the dilution of the vented gas:

- High ambient temperatures in relation to the vented gas
- Moderately stable atmospheric conditions
- Low wind speed

Calculations are usually carried out over the normal reported range of weather conditions to determine the worst case effect but extremes in the factors above can have significant impact on

estimated plume distances especially if the vent release conditions are as a plume (low velocity) rather than a gas jet (high velocity).

In order to minimise the weather effects and get the best possible dilution, it is recommended that the outlet design velocity of a vent be set as high as possible within the realms of process possibility (e.g. pressure loss, noise, etc.).

The prevailing wind at plant site can be taken into account, but it has to be considered that the wind can in practice come from any direction. For higher release velocities, horizontal or angled releases will have the result of negating much or all of any wind direction effect, although most computer modelling cannot take appropriate account of any crosswind condition except for truly vertical releases.

5.5 Venting of cryogenic liquid

To minimize the exposure of personnel or equipment to injury or damage, intentional venting of cryogenic liquids directly to atmosphere should be prohibited. Cryogenic liquids that are released in quantity during either routine operations or predicted upset conditions should be directed to a disposal system designed for this purpose. However care needs to be taken in the design of common headered liquid and vapour disposal systems to avoid the possibility of liquid backflow into gas vent headers, and to avoid risk of plugging of cryogenic relief valve discharges with ice from water accumulating in the header.

Some small liquid venting systems may be directed to a safe location without the need to pass through a disposal system:

- Vents from cryogenic thermal relief valves that might discharge cryogenic liquid in upset conditions may be vented at grade because of the small orifice size and short duration of any liquid release. However there should be consideration of any consequence of releasing a significant inventory of liquid in the event that the discharging relief valve fails to completely reseal after venting off the excess pressure.
- Small vents, drains, and trycocks from liquid fill lines, pump cooldown lines, or similar systems can be directed to catch trays or local spillage areas having adequate natural ventilation.

6 Calculations for the determination of safe vent locations

6.1 Introduction

Section 5 gives the factors to be considered as the basis for specifying safe locations for oxygen or asphyxiant atmospheric gas vents. The section also gives accepted concentration criteria that may be used for detailed dispersion calculations. Following generally available textbook methods such as the CCPS "Guidelines for Consequence Analysis of Chemical Releases" (1999 edition) [7] Chapter 2 or using equivalent computer programmes, it is possible to model accurately predicted safe separation distances for vent designs where all the appropriate release data are available. The calculations would be case specific but can result in separation distances optimised to minimise risk without requiring excessive safety margins. However for a large majority of atmospheric gas vents on an air separation plant, detailed calculation is either not practical through having insufficient information or because of the number of possible vents involved. In these circumstances application of prior art (previous designs) or use of look-up tables or graphs, separately generated as standards, will suffice **providing the assumptions against which the standard tables or graphs have been generated are met by the specific vent designs under review.**

As defined in Section 2.2 as part of the purpose of this document, expert opinion has been gathered and calculations carried out to prepare useable look-up tables that should cover a variety of cases where vent designs are required but for which detailed calculation is found to be inappropriate. It should always be noted that the preparation of standard tables will always involve compromises on the presentation of results, and that as a consequence the separation distances presented here while considered safe are likely to be conservative. In the event that use of these or other look-up tables

indicates that an identified vent location is too close to people or other equipment, the option to revert to carrying out detailed calculations for that specific case is always available.

The purpose of the paragraphs following in Section 6 is to provide the basis on which the vent elevations and separation distances in this document have been determined. It is important to recognise when unusual conditions exist that might vary significantly from those assumed for the calculations. In this event, the user shall review the available data and judge whether separate assessment is necessary.

When a gas is released, the resulting vapour cloud will be diluted by air entrainment. The rate of dilution is controlled by several factors which include gas properties, the release flow and velocity, meteorological conditions and terrain. There are also the various release scenarios to be considered, such as continuous releases, high momentum releases from the opening of a relief valve or low momentum releases from conservation vents. For these reasons, there is generally no one universal dispersion model to handle all types of releases; the appropriate model must be chosen for the particular release. Some computer programmes can combine the various models to allow automatic selection for the vent case under consideration.

6.2 Choice of software

Results of calculations using the DNV TECHNICA PHAST programme Version 6.42 are given in Appendices A – L for the criteria below. The calculations are for continuous releases under the conditions given; however the results will be valid for intermittent or instantaneous release cases at the same flow rates. Thus as discussed previously it is anticipated that the information presented for the location of vents that meet the design criteria can apply in the majority of cases where a conservative result is acceptable.

6.3 Weather conditions

The range of weather stability and wind speeds used in the calculations were selected as follows in accordance with best practice for capturing the worst case results from atmospheric dispersion calculations using PHAST.

Stability	Wind Speed
D	1.5 m/s
D	5 m/s
D	9 m/s
F	1.5 m/s

The stability is represented according to the Pasquill Stability Class (i.e., D: neutral conditions; F: moderately stable conditions).

Depending on the release rate, direction and physical conditions of the gas release being considered, the worst case vent elevations and separation distances can result from any of these weather conditions.

The largest safety separation distances for vents discharging horizontally are determined on the basis that the wind direction is coincident with that of the gas at the vent tip.

6.4 Release temperature

Gas vents from industrial gas plants can vary in temperature from significantly above ambient (for example, compressed gas discharges) down to dewpoint cryogenic gas temperatures (for example, vents from cryogenic columns).

Since the calculation results are given in terms of the vent size for a design minimum velocity of release (see Section 6.6 below), conservative separation distance results will be obtained from

selecting minimum values for warm or cold releases (highest density = highest mass flow for a given vent size and release velocity). The following release temperatures were the basis of calculation.

Material	Temperature
Oxygen (warm)	10.0 °C
Oxygen (cold)	-183.0 °C
Nitrogen (warm)	10.0 °C
Nitrogen (cold)	-195.6 °C
Argon (warm)	10.0 °C
Argon (cold)	-185.9 °C

The 10 degrees Centigrade warm temperature condition is considered representative of the temperatures achieved in separated gas streams exiting the warm-end of an air separation unit.

Should warmer release temperatures need to be considered, the calculation results will be conservative for a given line size and release velocity in that the released gases will be more buoyant and have less mass flow rate (resulting in shorter distances to dispersion).

6.5 Release angle

For all warm and cold vents, the orientation can be anywhere between the horizontal and the vertical. Calculations have been completed for horizontal, vertical and forty-five degree angle vent releases.

6.6 Release velocities

The venting systems have been divided into low-pressure and high-pressure sources for both warm and cold gases. Low-pressure systems are generally applicable to continuous or intermittent process vents for which silencers will usually be installed. High-pressure systems apply primarily to vents from pressure-relief devices or high pressure vents where no silencer is required on the outlet and release velocity restrictions do not exist. Release velocities for low-pressure and high-pressure systems were selected accordingly as follows.

Source	Velocity
Low pressure gas (O ₂ , N ₂ or Ar)	20 m/s ¹
Low pressure gas (O ₂ , N ₂ or Ar)	10 m/s
High pressure Oxygen (warm)	160 m/s ²
High Pressure Nitrogen (warm)	171 m/s
High Pressure Argon (warm)	160 m/s
High pressure Oxygen (cold)	90 m/s
High Pressure Nitrogen (cold)	89 m/s
High Pressure Argon (cold)	85 m/s

For vents in service with cold gas or the gases with molecular weight greater than air, allowance has been made for the negative buoyancy of the dense gas as initially released resulting in slumping (collapsing under gravity) of the plume. However, all separation distances presented for low pressure releases are based on release velocities at either 20 m/sec or 10 m/sec **and the results will not apply when release velocities are significantly lower** where the effects of initial momentum and air entrainment are significantly reduced and the mixing mechanisms can be different. Automatic process

¹ 20 metres per second is considered as representative design velocity for gas discharging from a vent silencer whereas a lower release velocity may be required by design in extreme noise suppression cases, or where a very low pressure direct gas release to atmosphere is required, for example waste venting from a water chiller tower.

² Vent discharge velocities of 0.5 Mach are taken as representative of the design cases for items such as pressure safety valves. The velocity has been calculated for the properties of the gas in air at the release temperatures selected.

vents from the vapour space of cryogenic-liquid storage tanks are examples that might require individual assessment to determine the desired vent elevation.

For design cases where release velocities are lower than 10 m/sec, a specific assessment of the cases will be required.

As stated in Section 5.1, the influence of release velocity is important in determining minimum stack height when gas can be vented at any flow rate between the nominal design capacity and zero. This is particularly important if the design full flow release conditions already require a low velocity with a dense gas relative to ambient air. The effect of reduced release velocity is discussed further with examples in Appendix N. For process vents with a large range of potential flowrates detailed vent calculations are recommended for the cases in question.

PHAST has limitations in the dispersion modelling which reduce the accuracy of calculation at very low gas release speeds evaluated by comparison with other calculation methods to be around 1 m/s. If release conditions need to be considered at this low velocity, the use of PHAST is not recommended and more complex methodologies will be required involving the use of methods such as three-dimensional Computational Fluid Dynamic (CFD) simulations.

6.7 Concentration limits

The jet dispersion model calculation within PHAST does not account for the components of air that are present in the released gas prior to the dispersion of the jet. The levels of concern that are published for oxygen enrichment or asphyxiation include the background concentration in the air. For example, 23.5% oxygen is a level of concern for possible ignition. However if this concentration was entered into the dispersion programme as the level of concern, the program would calculate a 23.5% concentration assuming that the original concentration in air was zero. Therefore a mathematical adjustment has to be made to determine the oxygen or asphyxiant concentrations of concern to be used as final values in the dispersion calculation. The ranges of hazard criteria used for oxygen-enriched and oxygen-deficient atmospheres given in the EIGA position paper listed in Section 4 are:

- Oxygen-enriched atmospheres: 23.5 - 25% oxygen by volume
- Oxygen-deficient atmospheres: 17 - 19.5% oxygen by volume

The dispersion calculations were performed on the basis of pure gaseous oxygen, nitrogen or argon releases. The mathematical method for the concentration adjustment is given in Appendix O.

Corresponding concentration limits for the dispersion calculations are as follows

Hazard Criteria	Calculated Range of Concern
25% Oxygen	0.05123 mol fraction O ₂
23.5% Oxygen	0.03226 mol fraction O ₂
19.5% Oxygen	0.07140 mol fraction N ₂ /Ar
18% Oxygen	0.14286 mol fraction N ₂ /Ar
17% Oxygen	0.19048 mol fraction N ₂ /Ar

6.8 Ambient conditions

Temperature difference between the gas as vented and the ambient temperature can have an effect on the dispersion. In order to examine this effect, base calculations were carried out for ambient air temperature of 10, 20 and 30 degrees Centigrade for a constant gas release temperature.

The calculations carried out showed that for many cases the ambient temperature effect was negligible in determining safe separation distances, and in all cases the variation never exceeded 10% of the worst case separation value calculated.

Thus the tables presented in the Appendices correspond to the highest value of separation distances (horizontally, above the vent and below the vent) found by calculation for any of the ambient air temperatures selected.

An average relative humidity of 70% was selected for the calculations.

All calculations were carried out for an atmospheric pressure of 1.013 bars abs (i.e. sea level conditions).

6.9 Interpretation of the tables

The individual PHAST dispersion calculations give concentration versus distance results in three dimensions for each scenario and each weather condition selected. For interpretation of gas cloud dimensions at any concentration limit the programme has the facility to produce graphical outputs that overlay the results for the same release scenario under various weather conditions onto a single diagram.

Examples of such output are given in the illustrations below. The cases are for warm low pressure oxygen released either vertically or horizontally giving side view dimensions of the dispersed cloud downwind at 23.5 volume % O₂ for each of the four weather conditions selected for review for each release direction.

The vent heights specified in the tables in the Appendices have been set to achieve a minimum safe elevation below any plume of 3 metres above working areas. This gives approximately 1 metre margin above body height to allow for slumping and also slight variations between cases in the modelling output.

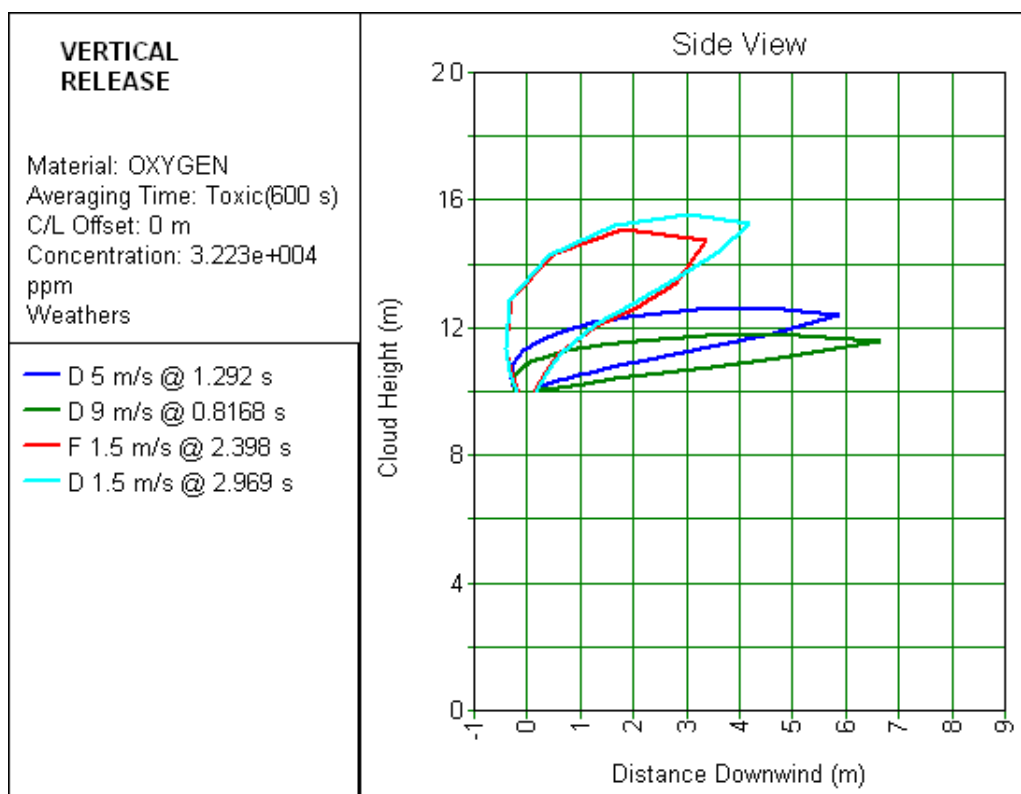

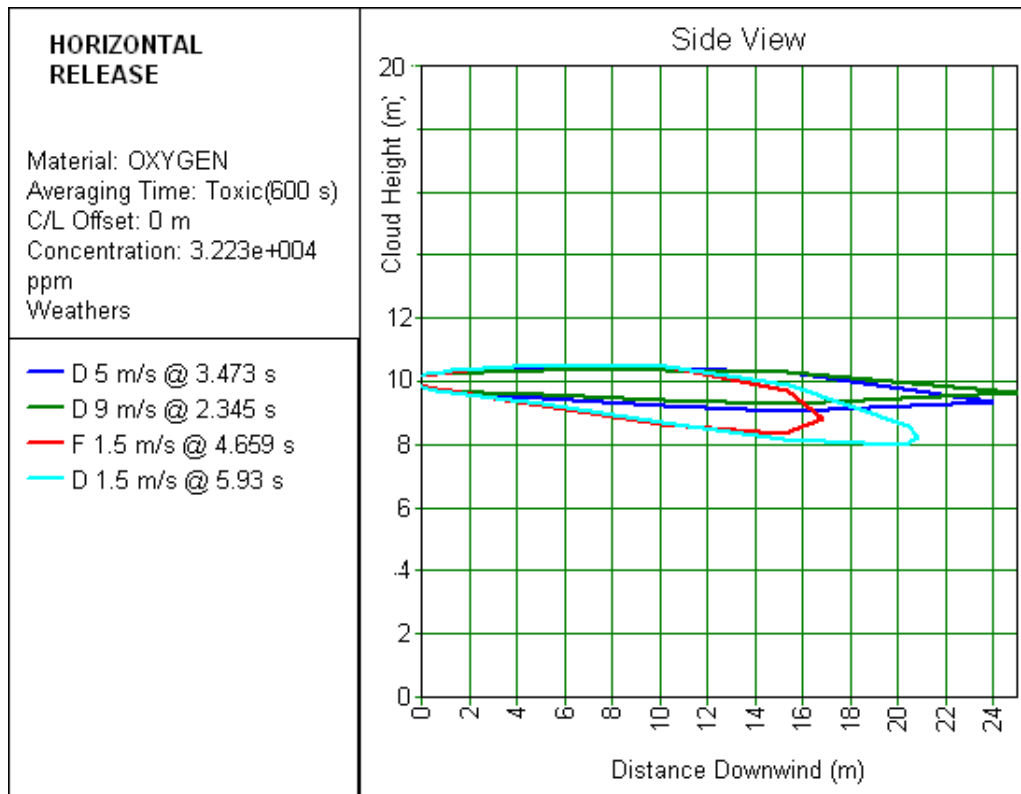

Other graphical views including those showing concentration changes with distance for any single release case under a stated weather condition are possible. However the form of graph shown illustrates best how to interpret the worst case separation distances given in the tables in the Appendices.

For each of the release scenarios listed in the Appendices, the corresponding table gives the following (derived from the appropriate graph):

- the maximum horizontal distance reached by the cloud dispersing to a given concentration for each nozzle size at any weather condition;
- the minimum necessary height of the vent release point for safety at any point below the dispersing cloud (accounting for negative buoyancy where observed from the results);
- the maximum vertical height above the release point reached by the cloud for any weather if appropriate – horizontal releases of atmospheric gases generally do not result in any significant cloud height above the release point and a standard maximum can be established for these cases as a simplification (see figures below).

Thus, examining the vertical graphical case illustrated, the maximum horizontal distance reached under any weather condition for 23.5% O₂ is indicated at 6.7 metres, the maximum vertical elevation above the release point is 5.5 metres, and the dispersed cloud never extends below the release point. As a result for the latter the minimum acceptable safe release height of 3 metres is indicated (but see discussions previously concerning vent locations). Note that the extreme horizontal and vertical dimensions are not obtained by a single weather case (this is the case for all releases and there is no general rule about which scenario results in which extreme dimension).

The horizontal release case result follows similarly except that the model cloud dimensions are never significantly above the release height whereas the worst case cloud has negative buoyancy justifying an increase in recommended minimum vent elevation from 3 to 5 metres.

Such graphs are inevitably idealised mathematical model shapes from the data and only approximate

to the cloud shapes actually resulting from venting under the same conditions. Thus rounding up of results is carried out in the tables. The results illustrated in fact correspond to Appendix A low pressure warm oxygen venting at 20 m/s from a 8 inch nominal bore pipe.

Figures 1, 2 and 3 that follow show how the separation data provided in the Appendices should be interpreted for horizontal, vertical or 45 degree angled vents respectively.

FIGURE 1: HORIZONTAL VENT SEPARATIONS

(a) SIDE VIEW:

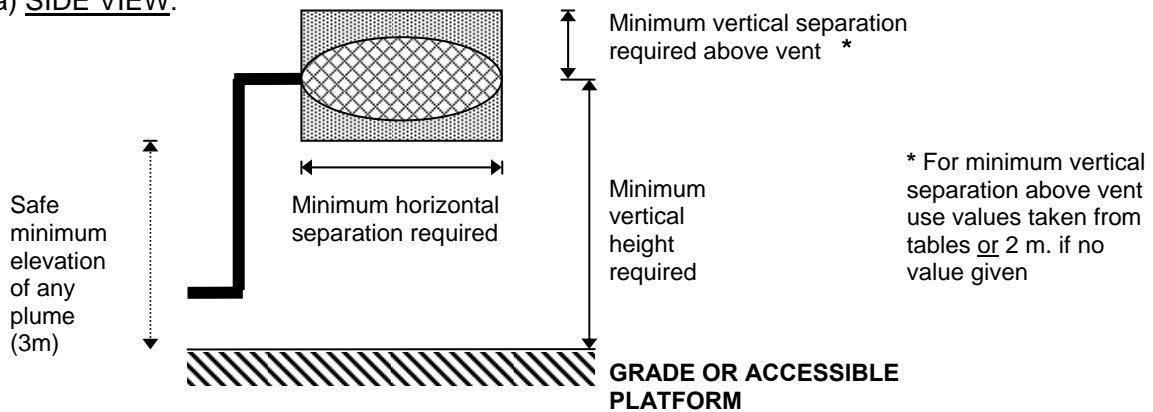

(b) PLAN VIEW:

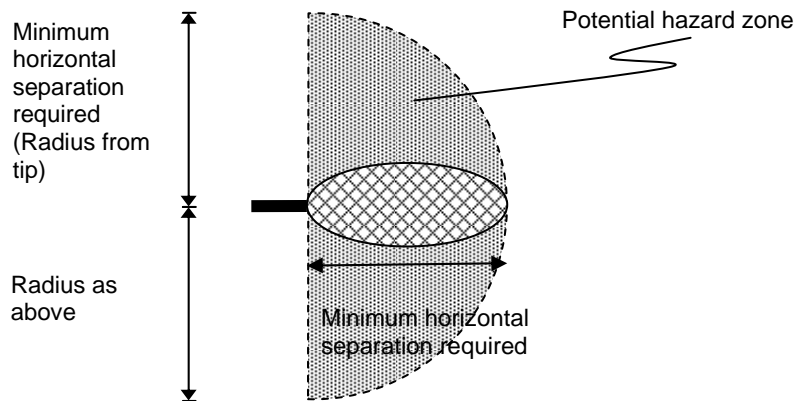
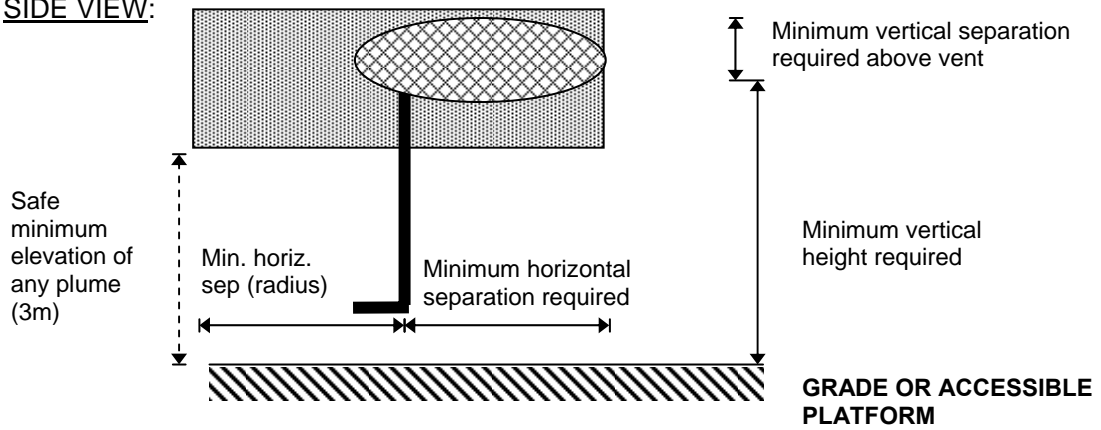

FIGURE 2: VERTICAL VENT SEPARATIONS

(a) SIDE VIEW:



(b) PLAN VIEW:

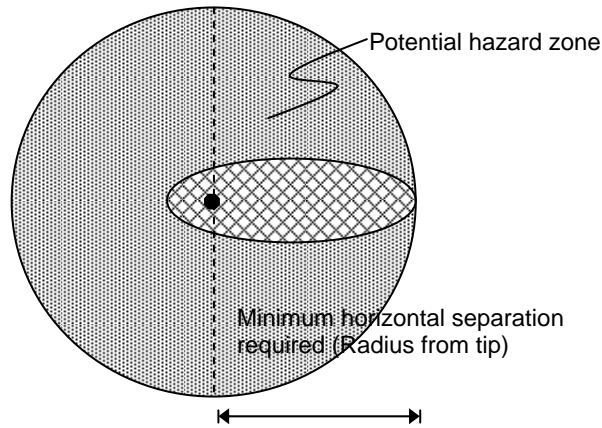
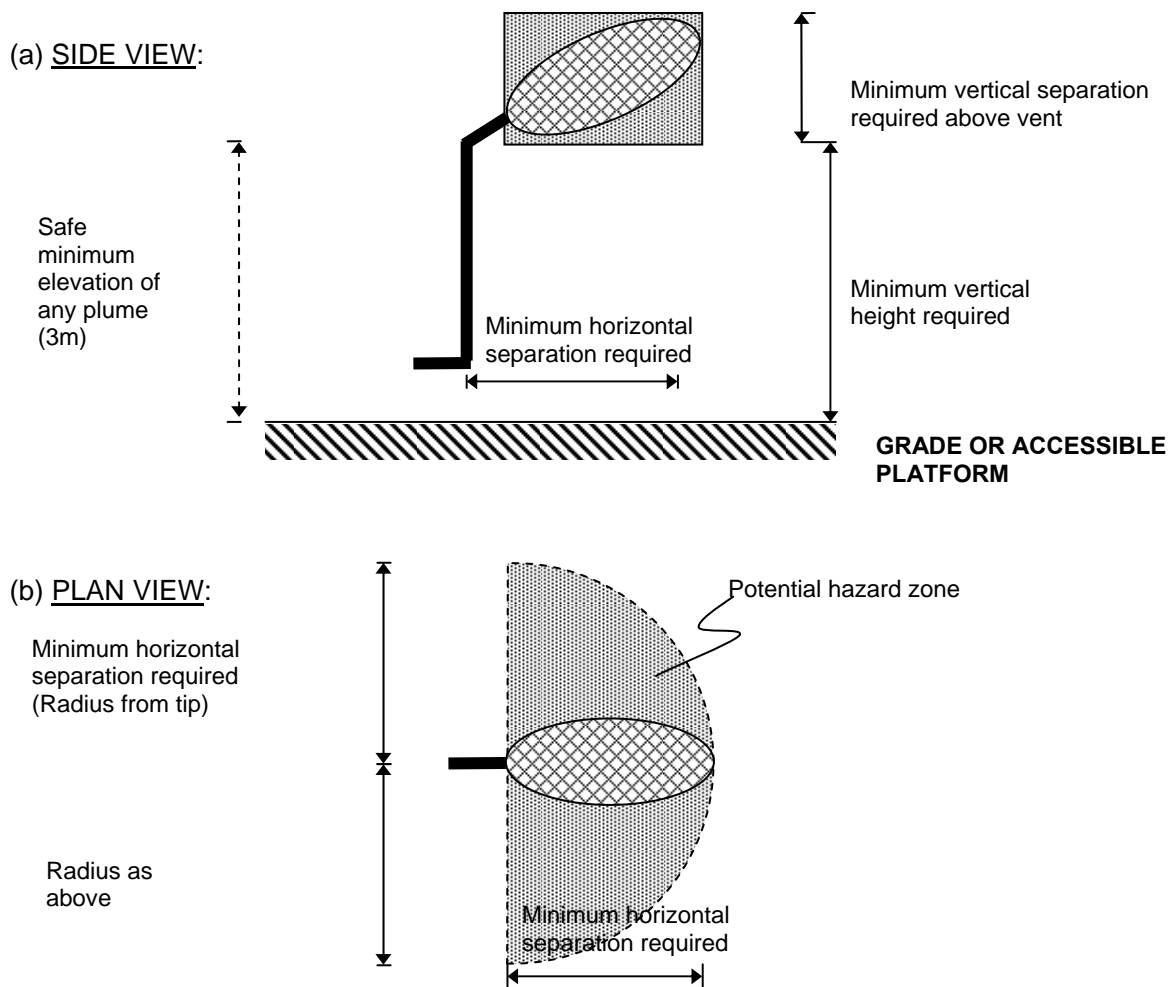

FIGURE 3: ANGLED VENT SEPARATIONS



6.10 Limitations on the calculation methodology

The main limitations on calculations that have been performed deal with the following.

- All dispersion calculations are based on a continuous release rate.
- Obstacles (buildings, structures...) are not taken into account in simulations.
- The modelling assumes that any release, if not vertical, is being vented in the same direction as the wind prevailing at the time of release.
- Fog: visual impact generated by the dispersion of cryogenic gas is not taken into account.

7 Conclusions

The recommended basis for determining the safe location of oxygen and inert atmospheric gas vents is given in Section 5 of this document.

From the calculation factors detailed in Section 6 the venting of oxygen and asphyxiating, non-toxic gases can be safely accomplished by adhering to the separation distances given in Appendices A through L for the selected vent sizes and vent orientation. This requires that a prior determination of the hazard concentration of concern is carried out in accordance with Section 5.2.

Cases where the vent conditions do not comply closely with factors given will require individual calculation and assessment.

8 References

1. EIGA Safety Advisory Group Newsletter 79/04 "Hazards of oxygen enriched atmospheres etc...".
2. EIGA Safety Advisory Group Newsletter 78/03 "Asphyxiation fatalities on a construction site etc...".
3. AIGA 030/06 "Storage of cryogenic air gases at user premises".
4. AIGA Document 005/04 "Fire hazards of oxygen and oxygen enriched atmospheres".
5. AIGA Document 008/04 "Hazard of inert gases".
6. EIGA Position Paper PP-14 "Definitions of oxygen enrichment/deficiency safety criteria".
7. Center for Chemical Process Safety book "Guidelines for consequence analysis of chemical releases" published by the American Institute of Chemical Engineers ISBN 0-8169-0786-2 (1999).

Appendix A: Warm Low Pressure Oxygen

A.1 WARM L.P.OXYGEN VENTING HORIZONTALLY AT 20m/s

Vent Size (mm)	Horizontal separation required in metres		Minimum vertical height required in metres	
	23.5 % O ₂	25% O ₂	23.5 % O ₂	25% O ₂
25	6	4	3	3
50	9	7	3	3
80	13	10	4	3
100	15	11	4	3
150	21	16	4	4
200	26	18	5	4
250	30	22	6	5
300	34	27	7	5
350	38	30	7	6
400	42	32	7	6
450	44	33	8	7
500	49	36	10	7
600	57	42	11	8
750	66	52	14	10
900	73	58	16	12
1200	88	68	22	16
1500	100	76	27	21

A.2 WARM OXYGEN VENTING HORIZONTALLY AT 10m/s

Vent Size (mm)	Horizontal separation required in metres		Minimum vertical height required in metres	
	23.5 % O ₂	25% O ₂	23.5 % O ₂	25% O ₂
25	6	4	3	3
50	9	7	3	3
80	12	9	4	3
100	14	10	4	3
150	19	14	4	4
200	24	16	5	4
250	26	20	5	5
300	28	23	6	5
350	32	26	7	5
400	34	27	8	6
450	36	28	9	7
500	40	30	9	8
600	47	32	10	8
750	53	45	13	10
900	58	48	15	12
1200	67	53	20	15
1500	90	69	25	19

A.3 WARM L.P.OXYGEN VENTING VERTICALLY AT 20m/s

Vent Size (mm)	Horizontal separation required in metres		Minimum vertical height required in metres		Minimum vertical separation required above vent in metres	
	23.5 % O2	25% O2	23.5 % O2	25% O2	23.5 % O2	25% O2
25	1	1	3	3	1	1
50	2	1	3	3	2	1
80	3	1	3	3	2	2
100	4	2	3	3	3	2
150	5	3	3	3	4	3
200	7	4	3	3	6	4
250	8	5	3	3	7	5
300	10	5	3	3	9	7
350	12	6	3	3	10	8
400	13	7	3	3	11	9
450	15	8	3	3	12	20
500	16	9	3	3	14	10
600	19	10	3	3	16	13
750	24	13	3	3	20	16
900	28	15	3	3	23	19
1200	37	20	3	3	31	25
1500	43	25	3	3	38	31

A.4 WARM L.P.OXYGEN VENTING VERTICALLY AT 10m/s

Vent Size (mm)	Horizontal separation required in metres		Minimum vertical height required in metres		Minimum vertical separation required above vent in metres	
	23.5 % O2	25% O2	23.5 % O2	25% O2	23.5 % O2	25% O2
25	2	1	3	3	1	1
50	3	2	3	3	1	1
80	4	2	3	3	2	1
100	5	3	3	3	2	2
150	6	4	3	3	3	2
200	8	5	3	3	4	3
250	10	6	3	3	5	4
300	12	6	3	3	6	4
350	14	7	3	3	6	5
400	15	8	3	3	7	6
450	17	10	3	3	8	6
500	19	10	3	3	8	7
600	23	12	3	3	10	8
750	27	15	3	3	12	10
900	30	18	3	3	13	12
1200	40	24	3	3	17	15
1500	45	30	3	3	20	18

A.5 WARM L.P.OXYGEN VENTING ANGLED AT 20m/s

Vent Size (mm)	Horizontal separation required in metres		Minimum vertical height required in metres		Minimum vertical separation required above vent in metres	
	23.5 % O2	25% O2	23.5 % O2	25% O2	23.5 % O2	25% O2
25	2	1	3	3	1	1
50	3	2	3	3	1	1
80	4	3	3	3	2	2
100	5	4	3	3	3	2
150	8	6	3	3	4	3
200	10	7	3	3	5	4
250	13	9	3	3	6	5
300	16	10	3	3	7	6
350	19	13	3	3	9	7
400	22	14	3	3	10	8
450	25	15	3	3	11	9
500	29	17	3	3	12	10
600	37	21	3	3	14	11
750	50	28	3	3	17	14
900	60	34	3	3	20	16
1200	78	50	3	3	24	21
1500	91	65	3	3	29	25

A.6 WARM L.P.OXYGEN VENTING ANGLED AT 10m/s

Vent Size (mm)	Horizontal separation required in metres		Minimum vertical height required in metres		Minimum vertical separation required above vent in metres	
	23.5 % O2	25% O2	23.5 % O2	25% O2	23.5 % O2	25% O2
25	2	1	3	3	1	1
50	4	2	3	3	1	1
80	5	3	3	3	2	1
100	6	4	3	3	2	2
150	9	5	3	3	3	2
200	12	7	3	3	3	3
250	16	9	3	3	4	3
300	20	11	3	3	5	4
350	24	13	3	3	6	5
400	27	16	3	3	6	5
450	29	18	3	3	7	6
500	32	21	3	3	7	6
600	36	25	3	3	8	7
750	42	31	3	3	10	9
900	46	36	3	3	11	10
1200	55	43	3	3	13	12
1500	65	50	3	3	15	14

Appendix B: Cold Low Pressure Oxygen

B.1 COLD L.P.OXYGEN VENTING HORIZONTALLY AT 20m/s

Vent Size (mm)	Horizontal separation required in metres		Minimum vertical height required in metres	
	23.5 % O ₂	25% O ₂	23.5 % O ₂	25% O ₂
25	8	6	4	4
50	11	9	5	4
80	16	11	6	5
100	18	13	7	6
150	22	18	10	8
200	27	21	12	10
250	32	24	15	12
300	35	27	18	14
350	37	30	21	16
400	40	31	24	19
450	43	33	28	21
500	44	36	30	24
600	50	40	36	29
750	56	45	46	36
900	65	49	56	43
1200	75	57	75	61
1500	83	65	94	76

B.1 COLD L.P.OXYGEN VENTING HORIZONTALLY AT 10m/s

Vent Size (mm)	Horizontal separation required in metres		Minimum vertical height required in metres	
	23.5 % O ₂	25% O ₂	23.5 % O ₂	25% O ₂
25	7	5	4	4
50	9	7	5	4
80	11	9	6	5
100	13	10	7	6
150	17	12	8	7
200	19	14	11	9
250	21	16	13	11
300	25	18	15	13
350	27	19	18	15
400	28	21	20	17
450	28	21	20	17
500	32	23	25	20
600	35	26	29	24
750	38	30	37	30
900	42	31	44	37
1200	49	37	59	49
1500	58	41	75	60

B.3 COLD L.P.OXYGEN VENTING VERTICALLY AT 20m/s

Vent Size (mm)	Horizontal separation required in metres		Minimum vertical height required in metres		Minimum vertical separation required above vent in metres	
	23.5 % O2	25% O2	23.5 % O2	25% O2	23.5 % O2	25% O2
25	2	1	3	3	2	2
50	4	2	3	3	3	3
80	6	3	3	3	5	4
100	8	5	3	3	6	5
150	14	7	3	3	8	7
200	18	11	3	3	10	9
250	22	13	4	3	11	10
300	26	16	6	3	12	12
350	31	18	8	4	13	13
400	33	20	10	5	14	14
450	36	23	13	7	15	14
500	39	26	15	9	15	15
600	43	31	21	13	17	17
750	49	36	25	16	18	18
900	52	39	37	26	20	19
1200	59	43	58	41	22	21
1500	65	46	78	58	24	24

B.4 COLD L.P.OXYGEN VENTING VERTICALLY AT 10m/s

Vent Size (mm)	Horizontal separation required in metres		Minimum vertical height required in metres		Minimum vertical separation required above vent in metres	
	23.5 % O2	25% O2	23.5 % O2	25% O2	23.5 % O2	25% O2
25	3	2	3	3	1	1
50	6	3	3	3	2	2
80	8	4	3	3	2	2
100	11	7	3	3	3	3
150	15	9	5	4	4	4
200	19	12	6	4	4	4
250	21	15	8	6	5	4
300	23	17	10	7	5	5
350	25	19	12	8	5	5
400	26	20	13	9	6	5
450	27	20	14	10	6	6
500	30	22	18	14	6	6
600	33	23	23	17	7	7
750	35	25	30	23	7	7
900	37	27	38	29	8	8
1200	44	31	52	42	9	9
1500	46	30	69	54	10	10

B.5 COLD L.P.OXYGEN VENTING ANGLED AT 20m/s

Vent Size (mm)	Horizontal separation required in metres		Minimum vertical height required in metres		Minimum vertical separation required above vent in metres	
	23.5 % O2	25% O2	23.5 % O2	25% O2	23.5 % O2	25% O2
25	4	2	3	3	2	1
50	8	6	3	3	2	2
80	12	8	3	3	3	3
100	15	10	3	3	4	4
150	21	15	4	3	5	5
200	26	19	6	3	5	5
250	31	22	8	5	6	6
300	34	25	10	7	6	6
350	35	29	12	8	7	7
400	39	31	15	10	7	7
450	42	34	17	11	8	7
500	44	35	21	14	8	8
600	48	37	26	18	8	8
750	53	42	35	25	9	9
900	58	46	43	32	9	9
1200	67	54	62	39	10	10
1500	78	59	83	62	10	10

B.6 COLD L.P.OXYGEN VENTING ANGLED AT 10m/s

Vent Size (mm)	Horizontal separation required in metres		Minimum vertical height required in metres		Minimum vertical separation required above vent in metres	
	23.5 % O2	25% O2	23.5 % O2	25% O2	23.5 % O2	25% O2
25	5	3	3	3	1	1
50	8	6	3	3	1	1
80	11	7	4	3	2	2
100	14	10	5	4	2	2
150	18	13	6	5	2	2
200	20	15	8	6	2	2
250	22	16	10	8	2	2
300	23	18	12	9	3	3
350	25	20	14	11	3	3
400	26	20	16	13	3	3
450	26	20	16	13	3	3
500	29	22	21	17	3	3
600	33	25	26	20	3	3
750	37	27	34	26	3	3
900	40	30	40	33	3	3
1200	45	35	55	45	3	3
1500	51	39	71	56	4	4

Appendix C: Warm High Pressure Oxygen

C.1 WARM H.P.OXYGEN VENTING HORIZONTALLY AT HIGH VELOCITY

Vent Size (mm)	Horizontal separation required in metres		Minimum vertical height required in metres	
	23.5 % O ₂	25% O ₂	23.5 % O ₂	25% O ₂
25	5	3	3	3
50	10	6	3	3
80	13	9	4	3
100	18	12	4	4
150	25	17	4	4
200	36	22	4	4
250	43	25	5	4
300	49	32	5	5
400	67	43	6	5

C.2 WARM H.P.OXYGEN VENTING VERTICALLY AT HIGH VELOCITY

Vent Size (mm)	Horizontal separation required in metres		Minimum vertical height required in metres		Minimum vertical separation required above vent in metres	
	23.5 % O ₂	25% O ₂	23.5 % O ₂	25% O ₂	23.5 % O ₂	25% O ₂
25	1	1	3	3	2	2
50	1	1	3	3	5	3
80	1	1	3	3	7	5
100	2	1	3	3	8	7
150	3	2	3	3	13	11
200	4	2	3	3	17	13
250	5	3	3	3	23	17
300	6	3	3	3	25	21
400	7	4	3	3	35	25

C.3 WARM H.P.OXYGEN VENTING ANGLED AT HIGH VELOCITY

Vent Size (mm)	Horizontal separation required in metres		Minimum vertical height required in metres		Minimum vertical separation required above vent in metres	
	23.5 % O ₂	25% O ₂	23.5 % O ₂	25% O ₂	23.5 % O ₂	25% O ₂
25	2	1	3	3	2	2
50	4	3	3	3	4	3
80	6	5	3	3	5	4
100	9	6	3	3	7	5
150	12	9	3	3	10	8
200	17	11	3	3	15	10
250	19	15	3	3	16	13
300	24	17	3	3	20	15
400	34	22	3	3	28	19

Appendix D: Cold High Pressure Oxygen

D.1 COLD H.P.OXYGEN VENTING HORIZONTALLY AT HIGH VELOCITY

Vent Size (mm)	Horizontal separation required in metres		Minimum vertical height required in metres	
	23.5 % O ₂	25% O ₂	23.5 % O ₂	25% O ₂
25	9	6	3	3
50	16	11	4	3
80	23	16	5	4
100	29	20	6	4
150	39	29	8	6
200	50	38	11	7
250	62	46	15	9
300	70	55	18	10
400	88	70	24	16

D.2 COLD H.P.OXYGEN VENTING VERTICALLY AT HIGH VELOCITY

Vent Size (mm)	Horizontal separation required in metres		Minimum vertical height required in metres		Minimum vertical separation required above vent in metres	
	23.5 % O ₂	25% O ₂	23.5 % O ₂	25% O ₂	23.5 % O ₂	25% O ₂
25	1	1	3	3	2	2
50	2	1	3	3	5	3
80	3	2	3	3	7	5
100	4	2	3	3	8	7
150	6	4	3	3	13	11
200	8	5	3	3	17	13
250	10	6	3	3	23	17
300	12	7	3	3	25	21
400	18	9	3	3	35	25

D.3 COLD H.P.OXYGEN VENTING ANGLED AT HIGH VELOCITY

Vent Size (mm)	Horizontal separation required in metres		Minimum vertical height required in metres		Minimum vertical separation required above vent in metres	
	23.5 % O ₂	25% O ₂	23.5 % O ₂	25% O ₂	23.5 % O ₂	25% O ₂
25	4	3	3	3	3	2
50	8	6	3	3	6	5
80	12	8	3	3	9	7
100	16	11	3	3	11	9
150	25	17	3	3	16	13
200	37	24	3	3	21	17
250	49	30	3	3	25	21
300	58	37	3	3	28	24
400	76	53	3	3	34	31

Appendix E: Warm Low Pressure Nitrogen

E.1 WARM L.P.NITROGEN VENTING HORIZONTALLY AT 20m/s

Vent Size (mm)	Horizontal separation required in metres			Minimum vertical height required in metres		
	19.5 %O ₂	18 %O ₂	17 %O ₂	19.5 %O ₂	18 %O ₂	17 %O ₂
25	3	2	1	4	4	4
50	6	3	1	4	4	4
80	8	5	3	4	4	4
100	10	6	4	4	4	4
150	14	8	6	4	4	4
200	17	10	7	4	4	4
250	20	12	9	4	4	4
300	24	13	10	4	4	4
350	26	15	11	4	4	4
400	30	16	12	5	4	4
450	34	17	14	5	4	4
500	36	19	16	5	4	4
600	38	23	18	5	4	4
750	45	28	22	6	4	4
900	55	32	24	7	5	5
1200	68	40	30	8	5	5
1500	85	48	38	12	6	5

E.2 WARM L.P.NITROGEN VENTING HORIZONTALLY AT 10m/s

Vent Size (mm)	Horizontal separation required in metres			Minimum vertical height required in metres		
	19.5 %O ₂	18 %O ₂	17 %O ₂	19.5 %O ₂	18 %O ₂	17 %O ₂
25	4	2	2	4	4	4
50	6	3	3	4	4	4
80	8	5	4	4	4	4
100	10	6	5	4	4	4
150	13	8	7	4	4	4
200	16	9	8	4	4	4
250	19	11	8	4	4	4
300	22	12	10	4	4	4
350	24	13	11	5	4	4
400	26	15	13	5	4	4
450	28	17	14	5	4	4
500	30	18	16	5	4	4
600	33	20	16	6	4	4
750	40	26	20	6	5	4
900	43	28	22	8	5	5
1200	55	34	27	9	6	5
1500	61	38	31	11	7	6

E.3 WARM L.P.NITROGEN VENTING VERTICALLY AT 20m/s

Vent size (mm)	Horizontal separation required in metres			Minimum vertical height required in metres			Minimum vertical separation required above vent in metres		
	19.5 %O ₂	18 %O ₂	17 %O ₂	19.5 %O ₂	18 %O ₂	17 %O ₂	19.5 %O ₂	18 %O ₂	17 %O ₂
25	1	1	1	3	3	3	1	1	1
50	1	1	1	3	3	3	1	1	1
80	1	1	1	3	3	3	2	1	1
100	2	1	1	3	3	3	2	2	1
150	2	1	1	3	3	3	3	2	2
200	3	1	1	3	3	3	4	3	2
250	3	1	1	3	3	3	5	3	3
300	4	1	1	3	3	3	5	4	3
350	4	2	1	3	3	3	6	4	4
400	5	2	1	3	3	3	7	5	4
450	6	2	2	3	3	3	8	5	4
500	6	3	2	3	3	3	8	6	4
600	7	3	2	3	3	3	10	7	6
750	9	4	2	3	3	3	12	8	6
900	10	4	2	3	3	3	16	10	8
1200	13	5	3	3	3	3	21	14	11
1500	16	6	4	3	3	3	25	18	14

E.4 WARM L.P.NITROGEN VENTING VERTICALLY AT 10m/s

Vent size (mm)	Horizontal separation required in metres			Minimum vertical height required in metres			Minimum vertical separation required above vent in metres		
	19.5 %O ₂	18 %O ₂	17 %O ₂	19.5 %O ₂	18 %O ₂	17 %O ₂	19.5 %O ₂	18 %O ₂	17 %O ₂
25	1	1	1	3	3	3	1	1	1
50	1	1	1	3	3	3	1	1	1
80	1	1	1	3	3	3	1	1	1
100	2	1	1	3	3	3	2	1	1
150	2	1	1	3	3	3	2	2	1
200	3	1	1	3	3	3	3	2	2
250	4	2	1	3	3	3	3	2	2
300	4	2	1	3	3	3	4	2	2
350	5	2	1	3	3	3	4	3	2
400	6	2	2	3	3	3	5	3	3
450	7	3	2	3	3	3	5	3	3
500	7	3	2	3	3	3	6	3	3
600	8	3	2	3	3	3	7	5	4
750	10	4	3	3	3	3	8	6	4
900	12	5	3	3	3	3	11	7	5
1200	15	5	4	3	3	3	14	8	7
1500	18	7	4	3	3	3	16	11	9

E.5 WARM L.P.NITROGEN VENTING ANGLED AT 20m/s

Vent size (mm)	Horizontal separation required in metres			Minimum vertical height required in metres			Minimum vertical separation required above vent in metres		
	19.5 %O ₂	18 %O ₂	17 %O ₂	19.5 %O ₂	18 %O ₂	17 %O ₂	19.5 %O ₂	18 %O ₂	17 %O ₂
25	1	1	1	3	3	3	1	1	1
50	2	1	1	3	3	3	1	1	1
80	2	1	1	3	3	3	1	1	1
100	3	2	1	3	3	3	2	1	1
150	4	2	2	3	3	3	3	2	1
200	6	3	2	3	3	3	3	2	2
250	7	4	3	3	3	3	4	3	2
300	8	4	3	3	3	3	5	3	3
350	10	5	4	3	3	3	6	4	3
400	11	5	4	3	3	3	7	4	3
450	12	6	4	3	3	3	8	4	3
500	13	6	5	3	3	3	9	4	4
600	15	8	6	3	3	3	10	6	5
750	18	10	7	3	3	3	12	6	5
900	24	13	9	3	3	3	14	9	7
1200	30	15	12	3	3	3	19	12	10
1500	42	20	15	3	3	3	24	15	12

E.6 WARM L.P.NITROGEN VENTING ANGLED AT 10m/s

Vent size (mm)	Horizontal separation required in metres			Minimum vertical height required in metres			Minimum vertical separation required above vent in metres		
	19.5 %O ₂	18 %O ₂	17 %O ₂	19.5 %O ₂	18 %O ₂	17 %O ₂	19.5 %O ₂	18 %O ₂	17 %O ₂
25	1	1	1	3	3	3	1	1	1
50	1	1	1	3	3	3	1	1	1
80	2	1	1	3	3	3	1	1	1
100	3	1	1	3	3	3	1	1	1
150	4	2	1	3	3	3	2	1	1
200	5	3	2	3	3	3	2	2	1
250	6	3	2	3	3	3	3	2	2
300	7	4	2	3	3	3	4	2	2
350	8	4	3	3	3	3	4	3	2
400	9	5	3	3	3	3	4	3	2
450	12	5	3	3	3	3	4	3	2
500	13	5	4	3	3	3	4	3	2
600	14	6	5	3	3	3	7	4	4
750	19	8	5	3	3	3	8	4	3
900	22	10	7	3	3	3	10	6	5
1200	31	14	10	3	3	3	12	8	7
1500	40	18	13	3	3	3	15	10	8

Appendix F: Cold Low Pressure Nitrogen

F.1 COLD L.P.NITROGEN VENTING HORIZONTALLY AT 20m/s

Vent Size (mm)	Horizontal separation required in metres			Minimum vertical height required in metres		
	19.5 %O ₂	18 %O ₂	17 %O ₂	19.5 %O ₂	18 %O ₂	17 %O ₂
25	5	3	3	4	4	4
50	8	5	5	4	4	4
80	10	7	6	5	4	4
100	12	9	7	6	5	4
150	16	11	10	7	6	5
200	18	13	11	9	7	6
250	22	16	14	11	8	7
300	24	18	16	13	9	8
350	26	20	17	15	10	9
400	28	21	19	17	12	10
450	30	24	21	19	13	11
500	33	26	22	21	14	12
600	35	28	26	26	17	15
750	40	31	28	31	23	18
900	45	37	33	40	27	22
1200	55	45	40	56	35	30
1500	63	50	47	83	45	37

F.2 COLD L.P.NITROGEN VENTING HORIZONTALLY AT 10m/s

Vent Size (mm)	Horizontal separation required in metres			Minimum vertical height required in metres		
	19.5 %O ₂	18 %O ₂	17 %O ₂	19.5 %O ₂	18 %O ₂	17 %O ₂
25	4	3	2	4	4	4
50	6	4	4	4	4	4
80	8	5	5	5	4	4
100	9	6	5	6	5	5
150	11	7	6	7	6	5
200	13	8	7	9	7	6
250	14	9	8	10	8	7
300	16	11	9	12	9	8
350	17	11	10	13	10	9
400	18	12	11	15	11	10
450	18	14	11	17	13	11
500	21	15	12	18	14	12
600	22	16	14	22	17	14
750	26	19	15	26	20	17
900	28	20	18	33	23	20
1200	33	24	21	45	33	27
1500	38	27	24	53	38	33

F.3 COLD L.P.NITROGEN VENTING VERTICALLY AT 20m/s

Vent size (mm)	Horizontal separation required in metres			Minimum vertical height required in metres			Minimum vertical separation required above vent in metres		
	19.5 %O ₂	18 %O ₂	17 %O ₂	19.5 %O ₂	18 %O ₂	17 %O ₂	19.5 %O ₂	18 %O ₂	17 %O ₂
25	1	1	1	3	3	3	2	2	2
50	2	1	1	3	3	3	3	2	2
80	2	1	1	3	3	3	4	3	3
100	3	1	1	3	3	3	5	4	3
150	5	2	2	3	3	3	7	5	5
200	8	3	2	3	3	3	9	7	6
250	11	4	2	3	3	3	10	8	8
300	13	4	3	3	3	3	12	10	10
350	14	4	3	3	3	3	12	12	11
400	17	5	4	3	3	3	14	12	11
450	23	7	5	3	3	3	15	12	11
500	25	8	6	3	3	3	15	12	11
600	25	10	7	11	3	3	15	15	14
750	33	15	9	14	3	3	16	15	14
900	35	16	10	23	8	5	18	18	17
1200	39	20	14	33	18	11	20	20	18
1500	41	23	17	53	25	13	25	22	22

F.4 COLD L.P.NITROGEN VENTING VERTICALLY AT 10m/s

Vent size (mm)	Horizontal separation required in metres			Minimum vertical height required in metres			Minimum vertical separation required above vent in metres		
	19.5 %O ₂	18 %O ₂	17 %O ₂	19.5 %O ₂	18 %O ₂	17 %O ₂	19.5 %O ₂	18 %O ₂	17 %O ₂
25	1	1	1	3	3	3	1	1	1
50	2	1	1	3	3	3	2	2	1
80	3	1	1	3	3	3	3	2	2
100	5	2	1	3	3	3	3	3	2
150	7	3	2	3	3	3	4	3	3
200	10	4	2	4	3	3	4	4	4
250	12	5	3	5	3	3	5	4	4
300	14	6	4	6	4	3	5	5	5
350	16	7	4	7	4	3	5	5	5
400	17	8	5	9	5	4	5	5	5
450	18	9	8	10	7	4	5	5	5
500	20	10	8	12	7	6	5	5	5
600	21	11	9	16	9	7	6	6	6
750	22	12	10	18	13	9	6	6	6
900	23	13	10	26	17	14	8	8	6
1200	26	14	11	38	25	20	8	8	8
1500	29	15	12	48	33	28	10	8	8

F.5 COLD L.P.NITROGEN VENTING ANGLED AT 20m/s

Vent size (mm)	Horizontal separation required in metres			Minimum vertical height required in metres			Minimum vertical separation required above vent in metres		
	19.5 %O ₂	18 %O ₂	17 %O ₂	19.5 %O ₂	18 %O ₂	17 %O ₂	19.5 %O ₂	18 %O ₂	17 %O ₂
25	2	1	1	3	3	3	1	1	1
50	5	2	2	3	3	3	2	2	2
80	7	3	3	3	3	3	3	2	2
100	10	5	4	3	3	3	4	3	3
150	14	9	6	3	3	3	5	4	4
200	17	12	9	3	3	3	6	5	5
250	20	14	12	4	3	3	6	6	6
300	24	16	14	5	3	3	7	6	6
350	26	18	16	6	3	3	7	7	6
400	30	20	18	8	3	3	7	7	7
450	34	22	18	9	3	3	7	7	7
500	36	24	20	11	3	3	7	7	7
600	40	26	24	15	6	3	8	8	8
750	44	30	26	19	9	3	9	8	8
900	46	35	32	28	15	10	10	10	9
1200	54	42	38	42	23	17	10	10	10
1500	60	48	48	57	31	25	10	10	10

F.6 WARM L.P.NITROGEN VENTING ANGLED AT 10m/s

Vent size (mm)	Horizontal separation required in metres			Minimum vertical height required in metres			Minimum vertical separation required above vent in metres		
	19.5 %O ₂	18 %O ₂	17 %O ₂	19.5 %O ₂	18 %O ₂	17 %O ₂	19.5 %O ₂	18 %O ₂	17 %O ₂
25	2	1	1	3	3	3	1	1	1
50	5	3	2	3	3	3	2	1	1
80	7	4	3	3	3	3	2	2	2
100	9	5	4	4	3	3	2	2	2
150	12	7	6	4	3	3	2	2	2
200	15	8	7	6	4	3	2	2	2
250	17	10	8	7	4	4	2	2	2
300	18	11	9	9	6	5	2	2	2
350	19	12	10	10	7	5	2	2	2
400	20	13	11	12	8	6	3	3	3
450	21	14	13	13	9	6	3	3	3
500	23	14	14	15	10	7	3	3	3
600	24	16	14	18	13	10	3	3	3
750	27	17	17	22	16	13	3	3	3
900	29	18	17	29	20	17	3	3	3
1200	32	22	20	40	28	23	3	3	3
1500	38	24	22	53	35	30	4	4	4

Appendix G: Warm High Pressure Nitrogen

G.1 WARM H.P.NITROGEN VENTING HORIZONTALLY AT HIGH VELOCITY

Vent Size (mm)	Horizontal separation required in metres			Minimum vertical height required in metres		
	19.5 %O ₂	18 %O ₂	17 %O ₂	19.5 %O ₂	18 %O ₂	17 %O ₂
25	3	1	1	4	4	4
50	5	2	2	4	4	4
80	6	3	3	4	4	4
100	9	4	3	4	4	4
150	12	6	5	4	4	4
200	17	8	6	4	4	4
250	21	10	7	4	4	4
300	24	11	8	4	4	4
400	33	15	11	5	4	4

G.2 WARM H.P.NITROGEN VENTING VERTICALLY AT HIGH VELOCITY

Vent size (mm)	Horizontal separation required in metres			Minimum vertical height required in metres			Minimum vertical separation required above vent in metres		
	19.5 %O ₂	18 %O ₂	17 %O ₂	19.5 %O ₂	18 %O ₂	17 %O ₂	19.5 %O ₂	18 %O ₂	17 %O ₂
25	1	1	1	3	3	3	2	1	1
50	1	1	1	3	3	3	3	2	1
80	1	1	1	3	3	3	4	3	2
100	1	1	1	3	3	3	6	3	3
150	1	1	1	3	3	3	8	5	3
200	1	1	1	3	3	3	11	6	5
250	2	1	1	3	3	3	12	7	6
300	2	1	1	3	3	3	16	9	6
400	3	1	1	3	3	3	22	11	9

G.2 WARM H.P.NITROGEN VENTING ANGLED AT HIGH VELOCITY

Vent size (mm)	Horizontal separation required in metres			Minimum vertical height required in metres			Minimum vertical separation required above vent in metres		
	19.5 %O ₂	18 %O ₂	17 %O ₂	19.5 %O ₂	18 %O ₂	17 %O ₂	19.5 %O ₂	18 %O ₂	17 %O ₂
25	1	1	1	3	3	3	1	1	1
50	2	1	1	3	3	3	2	1	1
80	4	2	1	3	3	3	3	2	1
100	5	2	2	3	3	3	4	2	2
150	7	4	2	3	3	3	7	4	2
200	9	4	3	3	3	3	8	4	3
250	11	6	4	3	3	3	10	6	4
300	14	7	5	3	3	3	13	7	5
400	18	9	7	3	3	3	16	8	7

Appendix H: Cold High Pressure Nitrogen

H.1 COLD H.P.NITROGEN VENTING HORIZONTALLY AT HIGH VELOCITY

Vent Size (mm)	Horizontal separation required in metres			Minimum vertical height required in metres		
	19.5 %O ₂	18 %O ₂	17 %O ₂	19.5 %O ₂	18 %O ₂	17 %O ₂
25	5	3	2	4	4	4
50	10	5	4	4	4	4
80	14	8	6	4	4	4
100	18	10	8	4	4	4
150	26	15	12	4	4	4
200	33	19	16	6	4	4
250	40	24	20	7	4	4
300	47	29	22	7	5	4
400	60	38	30	10	5	5

H.2 COLD H.P.NITROGEN VENTING VERTICALLY AT HIGH VELOCITY

Vent size (mm)	Horizontal separation required in metres			Minimum vertical height required in metres			Minimum vertical separation required above vent in metres		
	19.5 %O ₂	18 %O ₂	17 %O ₂	19.5 %O ₂	18 %O ₂	17 %O ₂	19.5 %O ₂	18 %O ₂	17 %O ₂
25	1	1	1	3	3	3	3	2	2
50	1	1	1	3	3	3	6	4	3
80	2	1	1	3	3	3	8	5	4
100	2	1	1	3	3	3	10	7	6
150	3	1	1	3	3	3	16	10	9
200	3	2	1	3	3	3	20	15	11
250	5	2	1	3	3	3	25	16	14
300	5	2	2	3	3	3	30	20	17
400	7	3	2	3	3	3	40	26	23

H.3 COLD H.P.NITROGEN VENTING ANGLED AT HIGH VELOCITY

Vent size (mm)	Horizontal separation required in metres			Minimum vertical height required in metres			Minimum vertical separation required above vent in metres		
	19.5 %O ₂	18 %O ₂	17 %O ₂	19.5 %O ₂	18 %O ₂	17 %O ₂	19.5 %O ₂	18 %O ₂	17 %O ₂
25	2	2	1	3	3	3	2	1	1
50	5	3	2	3	3	3	4	3	2
80	7	5	3	3	3	3	6	4	3
100	10	6	5	3	3	3	8	5	4
150	14	8	7	3	3	3	12	8	7
200	21	12	9	3	3	3	16	10	9
250	26	15	11	3	3	3	20	12	10
300	30	17	14	3	3	3	24	15	12
400	42	24	18	3	3	3	30	20	16

Appendix I: Warm Low Pressure Argon

I.1 WARM L.P.ARGON VENTING HORIZONTALLY AT 20m/s

Vent Size (mm)	Horizontal separation required in metres			Minimum vertical height required in metres		
	19.5 %O ₂	18 %O ₂	17 %O ₂	19.5 %O ₂	18 %O ₂	17 %O ₂
25	3	1	1	3	3	3
50	5	3	2	3	3	3
80	6	4	3	3	3	3
100	8	5	3	3	3	3
150	11	6	5	4	3	3
200	13	8	6	4	3	3

I.2 WARM L.P.ARGON VENTING HORIZONTALLY AT 10m/s

Vent Size (mm)	Horizontal separation required in metres			Minimum vertical height required in metres		
	19.5 %O ₂	18 %O ₂	17 %O ₂	19.5 %O ₂	18 %O ₂	17 %O ₂
25	3	2	1	3	3	3
50	5	3	3	3	3	3
80	6	4	3	3	3	3
100	7	5	4	3	3	3
150	9	6	5	4	3	3
200	11	7	6	4	3	3

I.3 WARM L.P.ARGON VENTING VERTICALLY AT 20m/s

Vent size (mm)	Horizontal separation required in metres			Minimum vertical height required in metres			Minimum vertical separation required above vent in metres		
	19.5 %O ₂	18 %O ₂	17 %O ₂	19.5 %O ₂	18 %O ₂	17 %O ₂	19.5 %O ₂	18 %O ₂	17 %O ₂
25	1	1	1	3	3	3	1	1	1
50	1	1	1	3	3	3	1	1	1
80	1	1	1	3	3	3	1	1	1
100	1	1	1	3	3	3	2	1	1
150	2	1	1	3	3	3	3	2	2
200	2	1	1	3	3	3	4	3	2

I.4 WARM L.P.ARGON VENTING VERTICALLY AT 10m/s

Vent size (mm)	Horizontal separation required in metres			Minimum vertical height required in metres			Minimum vertical separation required above vent in metres		
	19.5 %O ₂	18 %O ₂	17 %O ₂	19.5 %O ₂	18 %O ₂	17 %O ₂	19.5 %O ₂	18 %O ₂	17 %O ₂
25	1	1	1	3	3	3	1	1	1
50	1	1	1	3	3	3	1	1	1
80	1	1	1	3	3	3	1	1	1
100	1	1	1	3	3	3	1	1	1
150	2	1	1	4	3	3	2	2	2
200	2	1	1	4	3	3	2	2	2

I.5 WARM L.P.ARGON VENTING ANGLED AT 20m/s

Vent size (mm)	Horizontal separation required in metres			Minimum vertical height required in metres			Minimum vertical separation required above vent in metres		
	19.5 %O ₂	18 %O ₂	17 %O ₂	19.5 %O ₂	18 %O ₂	17 %O ₂	19.5 %O ₂	18 %O ₂	17 %O ₂
25	1	1	1	3	3	3	1	1	1
50	2	1	1	3	3	3	1	1	1
80	2	1	1	3	3	3	1	1	1
100	3	2	1	3	3	3	2	1	1
150	4	2	2	3	3	3	3	2	2
200	5	3	2	3	3	3	3	2	2

I.6 WARM L.P.ARGON VENTING ANGLED AT 10m/s

Vent size (mm)	Horizontal separation required in metres			Minimum vertical height required in metres			Minimum vertical separation required above vent in metres		
	19.5 %O ₂	18 %O ₂	17 %O ₂	19.5 %O ₂	18 %O ₂	17 %O ₂	19.5 %O ₂	18 %O ₂	17 %O ₂
25	1	1	1	3	3	3	1	1	1
50	1	1	1	3	3	3	1	1	1
80	2	1	1	3	3	3	1	1	1
100	2	1	1	3	3	3	1	1	1
150	4	2	1	4	3	3	2	1	1
200	5	2	2	4	3	3	2	2	1

Appendix J: Cold Low Pressure Argon

J.1 COLD L.P.ARGON VENTING HORIZONTALLY AT 20m/s

Vent Size (mm)	Horizontal separation required in metres			Minimum vertical height required in metres		
	19.5 %O ₂	18 %O ₂	17 %O ₂	19.5 %O ₂	18 %O ₂	17 %O ₂
25	4	3	2	3	3	3
50	7	4	4	4	3	3
80	9	6	5	4	4	3
100	11	7	6	5	4	4
150	14	10	8	6	5	4
200	17	12	11	8	6	5

J.2 COLD L.P.ARGON VENTING HORIZONTALLY AT 10m/s

Vent Size (mm)	Horizontal separation required in metres			Minimum vertical height required in metres		
	19.5 %O ₂	18 %O ₂	17 %O ₂	19.5 %O ₂	18 %O ₂	17 %O ₂
25	4	2	2	3	3	3
50	5	4	3	4	4	3
80	7	5	4	4	4	4
100	8	5	5	5	4	4
150	10	6	6	6	5	5
200	11	8	7	8	6	6

J.3 COLD L.P.ARGON VENTING VERTICALLY AT 20m/s

Vent size (mm)	Horizontal separation required in metres			Minimum vertical height required in metres			Minimum vertical separation required above vent in metres		
	19.5 %O ₂	18 %O ₂	17 %O ₂	19.5 %O ₂	18 %O ₂	17 %O ₂	19.5 %O ₂	18 %O ₂	17 %O ₂
25	1	1	1	3	3	3	1	1	1
50	1	1	1	3	3	3	2	2	1
80	2	1	1	3	3	3	4	3	2
100	2	1	1	3	3	3	5	4	3
150	3	1	1	3	3	3	7	5	4
200	5	2	1	3	3	3	9	7	6

J.4 COLD L.P.ARGON VENTING VERTICALLY AT 10m/s

Vent size (mm)	Horizontal separation required in metres			Minimum vertical height required in metres			Minimum vertical separation required above vent in metres		
	19.5 %O ₂	18 %O ₂	17 %O ₂	19.5 %O ₂	18 %O ₂	17 %O ₂	19.5 %O ₂	18 %O ₂	17 %O ₂
25	1	1	1	3	3	3	1	1	1
50	1	1	1	3	3	3	2	1	1
80	2	1	1	3	3	3	2	2	2
100	3	1	1	3	3	3	3	2	2
150	5	2	1	3	3	3	4	3	3
200	7	2	2	3	3	3	4	4	4

J.5 COLD L.P.ARGON VENTING ANGLED AT 20m/s

Vent size (mm)	Horizontal separation required in metres			Minimum vertical height required in metres			Minimum vertical separation required above vent in metres		
	19.5 %O ₂	18 %O ₂	17 %O ₂	19.5 %O ₂	18 %O ₂	17 %O ₂	19.5 %O ₂	18 %O ₂	17 %O ₂
25	2	1	1	3	3	3	1	1	1
50	4	2	2	3	3	3	2	2	1
80	6	3	2	3	3	3	3	2	2
100	8	4	3	3	3	3	4	3	3
150	12	7	5	3	3	3	5	4	3
200	15	11	8	3	3	3	6	5	5

J.6 COLD L.P.ARGON VENTING ANGLED AT 10m/s

Vent size (mm)	Horizontal separation required in metres			Minimum vertical height required in metres			Minimum vertical separation required above vent in metres		
	19.5 %O ₂	18 %O ₂	17 %O ₂	19.5 %O ₂	18 %O ₂	17 %O ₂	19.5 %O ₂	18 %O ₂	17 %O ₂
25	2	1	1	3	3	3	1	1	1
50	4	2	2	3	3	3	2	1	1
80	6	4	3	3	3	3	2	2	1
100	7	4	4	3	3	3	2	2	2
150	10	6	5	3	3	3	2	2	2
200	12	7	6	3	3	3	2	2	2

Appendix K: Warm High Pressure Argon

K.1 WARM H.P.ARGON VENTING HORIZONTALLY AT HIGH VELOCITY

Vent Size (mm)	Horizontal separation required in metres			Minimum vertical height required in metres		
	19.5 %O ₂	18 %O ₂	17 %O ₂	19.5 %O ₂	18 %O ₂	17 %O ₂
25	2	1	1	3	3	3
50	4	2	1	3	3	3
80	6	3	2	3	3	3
100	7	3	3	3	3	3
150	11	5	4	3	3	3
200	14	7	5	4	3	3

K.2 WARM H.P.ARGON VENTING VERTICALLY AT HIGH VELOCITY

Vent size (mm)	Horizontal separation required in metres			Minimum vertical height required in metres			Minimum vertical separation required above vent in metres		
	19.5 %O ₂	18 %O ₂	17 %O ₂	19.5 %O ₂	18 %O ₂	17 %O ₂	19.5 %O ₂	18 %O ₂	17 %O ₂
25	1	1	1	3	3	3	1	1	1
50	1	1	1	3	3	3	3	2	1
80	1	1	1	3	3	3	4	2	2
100	1	1	1	3	3	3	5	3	2
150	1	1	1	3	3	3	8	4	3
200	1	1	1	3	3	3	10	5	4

K.3 WARM H.P.ARGON VENTING ANGLED AT HIGH VELOCITY

Vent size (mm)	Horizontal separation required in metres			Minimum vertical height required in metres			Minimum vertical separation required above vent in metres		
	19.5 %O ₂	18 %O ₂	17 %O ₂	19.5 %O ₂	18 %O ₂	17 %O ₂	19.5 %O ₂	18 %O ₂	17 %O ₂
25	1	1	1	3	3	3	1	1	1
50	2	1	1	3	3	3	2	1	1
80	3	2	1	3	3	3	3	2	1
100	4	2	2	3	3	3	4	2	2
150	6	3	2	3	3	3	6	3	2
200	8	4	3	3	3	3	8	4	3

Appendix L: Cold High Pressure Argon

L.1 COLD H.P.ARGON VENTING HORIZONTALLY AT HIGH VELOCITY

Vent Size (mm)	Horizontal separation required in metres			Minimum vertical height required in metres		
	19.5 %O ₂	18 %O ₂	17 %O ₂	19.5 %O ₂	18 %O ₂	17 %O ₂
25	4	2	2	3	3	3
50	8	4	3	3	3	3
80	11	6	5	3	3	3
100	15	8	7	4	3	3
150	21	12	10	4	3	3
200	28	17	13	5	4	3

L.2 COLD H.P.ARGON VENTING VERTICALLY AT HIGH VELOCITY

Vent size (mm)	Horizontal separation required in metres			Minimum vertical height required in metres			Minimum vertical separation required above vent in metres		
	19.5 %O ₂	18 %O ₂	17 %O ₂	19.5 %O ₂	18 %O ₂	17 %O ₂	19.5 %O ₂	18 %O ₂	17 %O ₂
25	1	1	1	3	3	3	2	2	1
50	1	1	1	3	3	3	5	3	2
80	1	1	1	3	3	3	7	4	4
100	1	1	1	3	3	3	9	6	5
150	2	1	1	3	3	3	14	9	7
200	2	1	1	3	3	3	18	12	10

L.3 COLD H.P.ARGON VENTING ANGLED AT HIGH VELOCITY

Vent size (mm)	Horizontal separation required in metres			Minimum vertical height required in metres			Minimum vertical separation required above vent in metres		
	19.5 %O ₂	18 %O ₂	17 %O ₂	19.5 %O ₂	18 %O ₂	17 %O ₂	19.5 %O ₂	18 %O ₂	17 %O ₂
25	2	1	1	3	3	3	2	1	1
50	4	3	2	3	3	3	4	2	2
80	6	4	3	3	3	3	5	3	3
100	9	5	4	3	3	3	7	5	4
150	12	8	6	3	3	3	11	7	6
200	17	10	8	3	3	3	14	9	8

APPENDIX M: Equivalent Release Rates

Equivalent Release Rates for Oxygen @ 10 Deg.C, venting at 20m/s & 10m/s

Vent Size (mm)	Release Rate @ 20m/s	Release Rate @ 10m/s
25	50 kg/h	25 kg/h
50	200 kg/h	100 kg/h
80	450 kg/h	220 kg/h
100	800 kg/h	400 kg/h
150	1800 kg/h	910 kg/h
200	3200 kg/h	1600 kg/h
250	5000 kg/h	2500 kg/h
300	7200 kg/h	3600 kg/h
350	9900 kg/h	4900 kg/h

Vent Size (mm)	Release Rate @ 20m/s	Release Rate @ 10m/s
400	12900 kg/h	6400 kg/h
450	16300 kg/h	8200 kg/h
500	20100 kg/h	10100 kg/h
600	29000 kg/h	14500 kg/h
750	45300 kg/h	22700 kg/h
900	65200 kg/h	32600 kg/h
1200	116000 kg/h	58000 kg/h
1500	181000 kg/h	91000 kg/h

Equivalent Release Rates for Oxygen @ -183 Deg.C venting at 20m/s & 10m/s

Vent Size (mm)	Release Rate @ 20m/s	Release Rate @ 10m/s
25	160 kg/h	80kg/h
50	650 kg/h	330 kg/h
80	1500 kg/h	730 kg/h
100	2600 kg/h	1300 kg/h
150	5900 kg/h	2900 kg/h
200	10400 kg/h	5200 kg/h
250	16300 kg/h	8100 kg/h
300	23400 kg/h	11700 kg/h
350	31900 kg/h	16000 kg/h

Vent Size (mm)	Release Rate @ 20m/s	Release Rate @ 10m/s
400	41700 kg/h	20800 kg/h
450	52800 kg/h	26400 kg/h
500	65100 kg/h	32600 kg/h
600	93700 kg/h	46900 kg/h
750	146000 kg/h	73300 kg/h
900	211000 kg/h	106000 kg/h
1200	375000 kg/h	187000 kg/h
1500	584000 kg/h	292000 kg/h

Equivalent Release Rates for Oxygen @ 10 Deg.C, venting at 160m/s

Vent Size	Release Rate
25 mm	400 kg/h
50 mm	1600 kg/h
80 mm	3600 kg/h
100 mm	6400 kg/h
150 mm	14500 kg/h

Vent Size	Release Rate
200 mm	25800 kg/h
250 mm	40300 kg/h
300 mm	58000 kg/h
400 mm	103000 kg/h

Equivalent Release Rates for Oxygen @ -183 Deg.C, venting at 90m/s

Vent Size	Release Rate
25 mm	730 kg/h
50 mm	2900 kg/h
80 mm	6600 kg/h
100 mm	11700 kg/h
150 mm	26400 kg/h

Vent Size	Release Rate
200 mm	46900 kg/h
250 mm	73300 kg/h
300 mm	105000 kg/h
400 mm	188000 kg/h

Equivalent Release Rates for Nitrogen @ 10 Deg.C, venting at 20m/s & 10m/s

Vent Size (mm)	Release Rate @ 20m/s	Release Rate @ 10m/s
25	40 kg/h	20 kg/h
50	180 kg/h	90 kg/h
80	400 kg/h	200 kg/h
100	700 kg/h	350 kg/h
150	1600 kg/h	790 kg/h
200	2800 kg/h	1400 kg/h
250	4400 kg/h	2200 kg/h
300	6300 kg/h	3200 kg/h
350	8600 kg/h	4300 kg/h

Vent Size (mm)	Release Rate @ 20m/s	Release Rate @ 10m/s
400	11300 kg/h	5600 kg/h
450	14300 kg/h	7200 kg/h
500	17600 kg/h	8800 kg/h
600	25300 kg/h	12700 kg/h
750	39600 kg/h	19800 kg/h
900	57000 kg/h	28500 kg/h
1200	101000 kg/h	50700 kg/h
1500	158000 kg/h	79200 kg/h

Equivalent Release Rates for Nitrogen @ -195 Deg.C venting at 20m/s & 10m/s

Vent Size (mm)	Release Rate @ 20m/s	Release Rate @ 10m/s
25	170 kg/h	80kg/h
50	670 kg/h	340 kg/h
80	1500 kg/h	750 kg/h
100	2700 kg/h	1300 kg/h
150	6000 kg/h	3000 kg/h
200	10700 kg/h	5400 kg/h
250	16800 kg/h	8400 kg/h
300	24100 kg/h	12100 kg/h
350	32900 kg/h	16400 kg/h

Vent Size (mm)	Release Rate @ 20m/s	Release Rate @ 10m/s
400	42900 kg/h	21500 kg/h
450	54300 kg/h	27200 kg/h
500	67100 kg/h	33500 kg/h
600	96600 kg/h	48300 kg/h
750	151000 kg/h	75400 kg/h
900	217000 kg/h	109000 kg/h
1200	386000 kg/h	193000 kg/h
1500	604000 kg/h	302000 kg/h

Equivalent Release Rates for Nitrogen @ 10 Deg.C, venting at 170m/s

Vent Size	Release Rate
25 mm	380 kg/h
50 mm	1500 kg/h
80 mm	3400 kg/h
100 mm	6000 kg/h
150 mm	13500 kg/h

Vent Size	Release Rate
200 mm	24100 kg/h
250 mm	37600 kg/h
300 mm	54200 kg/h
400 mm	96300 kg/h

Equivalent Release Rates for Nitrogen @ -195 Deg.C, venting at 90m/s

Vent Size	Release Rate
25 mm	750 kg/h
50 mm	3000 kg/h
80 mm	6700 kg/h
100 mm	12000 kg/h
150 mm	27000 kg/h

Vent Size	Release Rate
200 mm	47900 kg/h
250 mm	74900 kg/h
300 mm	108000 kg/h
400 mm	192000 kg/h

Equivalent Release Rates for Argon @ 10 Deg.C, venting at 20m/s & 10m/s

Vent Size (mm)	Release Rate @ 20m/s	Release Rate @ 10m/s
25	60 kg/h	30 kg/h
50	250 kg/h	130 kg/h
80	570 kg/h	280 kg/h

Vent Size (mm)	Release Rate @ 20m/s	Release Rate @ 10m/s
100	1000 kg/h	500 kg/h
150	2300 kg/h	1100 kg/h
200	4000 kg/h	2000 kg/h

Equivalent Release Rates for Argon @ -186 Deg.C, venting at 20m/s & 10m/s

Vent Size (mm)	Release Rate @ 20m/s	Release Rate @ 10m/s
25	210 kg/h	110 kg/h
50	840 kg/h	420 kg/h
80	1900 kg/h	950 kg/h

Vent Size (mm)	Release Rate @ 20m/s	Release Rate @ 10m/s
100	3400 kg/h	1700 kg/h
150	7600 kg/h	3800 kg/h
200	13500 kg/h	6700 kg/h

Equivalent Release Rates for Argon @ 10 Deg.C, venting at 160m/s

Vent Size	Release Rate
25 mm	500 kg/h
50 mm	2000 kg/h
80 mm	4500 kg/h

Vent Size	Release Rate
100 mm	8000 kg/h
150 mm	18100 kg/h
200 mm	32200 kg/h

Equivalent Release Rates for Argon @ -186 Deg.C, venting at 85m/s

Vent Size	Release Rate
25 mm	900 kg/h
50 mm	3600 kg/h
80 mm	8000 kg/h

Vent Size	Release Rate
100 mm	14300 kg/h
150 mm	32200 kg/h
200 mm	57200 kg/h

APPENDIX N: Influence of Release Speed

The following tables illustrate the influence of the release speed on the calculation within PHAST for separation distance and especially on the minimal vertical height that would be required for venting oxygen in safe location for 23.5% O₂ cloud being not lower than 3 meters above ground.

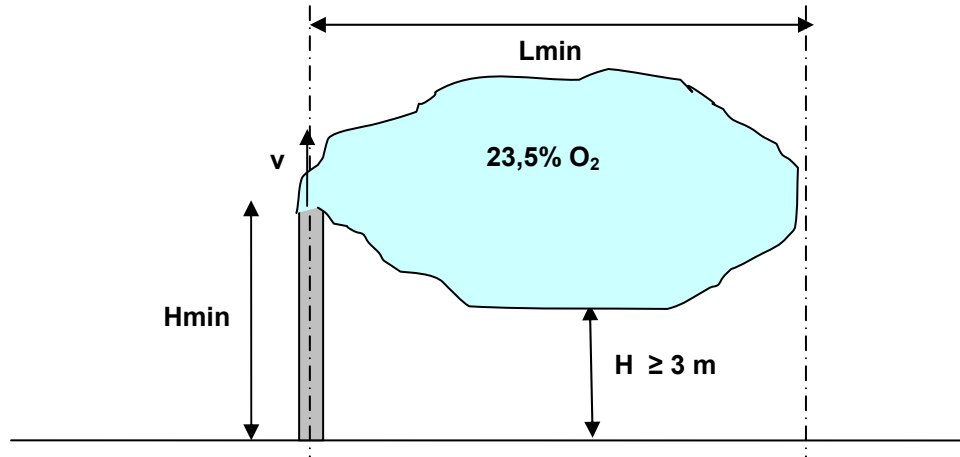

12 inch vent size	v (m/s)	Hmin (m)	Lmin (m)
Low Pressure Warm O ₂ Vertical	20	3	10
	10	3	12
	5	3	12
	2	3	9

24 inch vent size	v (m/s)	Hmin (m)	Lmin (m)
Low Pressure Warm O ₂ Vertical	20	3	19
	10	3	23
	5	4	20
	2	5	21

36 inch vent size	v (m/s)	Hmin (m)	Lmin (m)
Low Pressure Warm O ₂ Vertical	20	3	28
	10	3	30
	5	6	23
	2	7	25

Values are those obtained by calculation using the factors given in Section 6 of this document. Highlighted values illustrate that accounting for a potential decrease of the release speed (e.g. reduced flowrate at turndown) can result in requiring a significant increase of the vertical height of the vent in addition to a potential adjustment to the horizontal separation distance requirement.

Depending on the release rate, direction and physical conditions of the gas release being considered, the worst case vent elevations and separation distances can result from any of the weather conditions discussed in Section 6.3. Because of this the tables above do not show any consistent rule governing variations of the worst case horizontal dimensions with velocity or line size.

APPENDIX O: O₂ Adjustment Mathematics

Generally dispersion programs are designed for the release of materials not found in air. For example, when methane is vented the assumption is that the background concentration of methane prior to the release is zero. However, when oxygen is vented, a background concentration of approximately 21% oxygen is present in the air.

The levels of concern that are published for oxygen enrichment or asphyxiation include the background concentration in the air. For example, 23.5% oxygen is a level of concern for possible ignition. If this level of concern was entered into the dispersion programs as the level of concern, the program would calculate a 23.5% concentration assuming that the original concentration was 0.

The number to enter into the dispersion programs is not simply the difference between the level of concern and the background concentration. As the material is released, material is being added to the air. The *O₂ Adjustment Mathematics* below account for the added material.

There are two options - the calculation for O₂ dispersion in air and the calculation for the dispersion of an asphyxiant in air.

O₂ dispersion in air

Inputs: O₂ mole fraction in air: O2AIR (typical value = 0.21)
 O₂ mole fraction released: O2RELEASE
 O₂ mole fraction of concern: O2LEL (typical value = 0.235)

Output: O₂ mole fraction for dispersion programs: O2LOC

Derivation of equation:

X = moles of air
 Y = moles released

$$\text{Moles O}_2 \text{ initial} + \text{Moles O}_2 \text{ released} = \text{Moles O}_2 \text{ final} \quad (1)$$

$$(O2AIR)(X) + (O2RELEASE)(Y) = (O2LEL)(X+Y) \quad (2)$$

$$X * (O2LEL - O2AIR) = Y * (O2RELEASE - O2LEL) \quad (3)$$

$$Y = \frac{(O2LEL - O2AIR)}{(O2RELEASE - O2LEL)} X \quad (4)$$

$$\text{Final concentration} = \frac{\text{moles released}}{\text{total moles}} \frac{\text{asphyxiant moles}}{\text{moles released}} \quad (5)$$

$$\text{Final concentration} = \frac{Y}{(X + Y)} O2RELEASE \quad (6)$$

$$\frac{Y}{(X + Y)} O2RELEASE = \frac{\frac{(O2LEL - O2AIR)}{(O2RELEASE - O2LEL)} X}{X \left[1 + \frac{(O2LEL - O2AIR)}{(O2RELEASE - O2LEL)} \right]} O2RELEASE \quad (7)$$

$$\frac{Y}{(X + Y)} O2RELEASE = \frac{(O2LEL - O2AIR)}{(O2RELEASE - O2AIR)} O2RELEASE \quad (8)$$

Asphyxiant dispersion in air

Inputs: Asphyxiant mole fraction in air: N2AIR (typical value = 0.79)
 Asphyxiant mole fraction released: N2RELEASE
 O₂ mole fraction of concern: O2LEVEL

Outputs: Asphyxiant mole fraction for dispersion programs: N2LOC

Derivation of equation:

X = moles of air
 Y = moles released

$$\text{Moles asphyxiant initial} + \text{Moles asphyxiant released} = \text{Moles asphyxiant final} \quad (9)$$

$$(N2AIR)(X) + (N2RELEASE)(Y) = (1 - O2LEVEL)(X + Y) \quad (10)$$

$$X * (N2AIR + O2LEVEL - 1) = Y * (1 - O2LEVEL - N2RELEASE) \quad (11)$$

$$Y = \frac{(N2AIR + O2LEVEL - 1)}{(1 - O2LEVEL - N2RELEASE)} X \quad (12)$$

$$\text{Final concentration} = \frac{\text{moles released}}{\text{total moles}} \frac{\text{asphyxiant moles}}{\text{moles released}} \quad (13)$$

$$\text{Final concentration} = \frac{Y}{(X + Y)} N2RELEASE \quad (14)$$

$$= \frac{\frac{(N2AIR + O2LEVEL - 1)}{(1 - O2LEVEL - N2RELEASE)} X}{X \left[1 + \frac{(N2AIR + O2LEVEL - 1)}{(1 - O2LEVEL - N2RELEASE)} \right]} N2RELEASE \quad (15)$$

$$= \frac{(N2AIR + O2LEVEL - 1)}{(N2AIR - N2RELEASE)} N2RELEASE \quad (16)$$